

# Miniature resistance thermometer

## For sanitary applications, with integrated sterile connection

### Model TR21-C

WIKA data sheet TE 60.28



for further approvals  
see page 6

### Applications

- Sanitary applications
- Food and beverage industry
- Pharmaceutical industry, production of active ingredients
- Biotechnology and life science engineering
- Creamery, brewery

### Special features

- Compact design for space-saving mounting
- Simple and fast electrical connection using an M12 x 1 plug connection
- With direct sensor output (Pt100/Pt1000 in 3 or 4-wire version) or integrated transmitter with 4 ... 20 mA output signal, individually parameterisable with free-of-charge WIKAsoft-TT PC configuration software
- Materials and surface finish quality in accordance with standards of hygienic designs



Fig. left: Without neck tube, with clamp connection

Fig. right: Tapered design, G 1/2

### Description

The model TR21-C resistance thermometer provides temperature measurement in sanitary applications and can be used for the measurement of liquid and gaseous media in the range of -30 ... +250 °C [-22 ... +482 °F]. For use in hazardous areas, intrinsically safe versions are available.

These thermometers are fitted with process connections that meet the stringent requirements, in terms of materials and design, of hygienic measuring points. All electrical components are protected against moisture (IP67 or IP69K).

The resistance thermometer is available with direct sensor output or integrated transmitter, which can be configured individually via the WIKAsoft-TT PC configuration software. Measuring range, dampening, error signalling per NAMUR NE 043 and tag no. can be adjusted.

The welded junction between the protection tube and the flange makes the use of a sealing as additional material in those areas redundant which are in contact with the product. Through the compact design, this resistance thermometer is designed specifically for operation in applications with limited mounting space. Insertion length, process connection, sensor and connection method can each be selected for the respective application within the ordering information. The electrical connection is made via an M12 x 1 circular connector.

For applications requiring the sterilisation of the instrument in autoclaves, an especially temperature-resistant instrument version is available.

# Specifications

Measuring element		
<b>Type of measuring element</b>		
4 ... 20 mA version (models TR21-C-xTT, TR21-C-xTB)	<ul style="list-style-type: none"> <li>■ Pt1000 (measuring current &lt; 0.3 mA; self-heating can be ignored)</li> <li>■ Face-sensitive Pt1000 <sup>1)</sup> (measuring current &lt; 0.3 mA; self-heating can be ignored)</li> </ul>	
Pt100 (model TR21-C-xPx)/Pt1000 (model TR21-C-xRx) version	<ul style="list-style-type: none"> <li>■ Pt100 (measuring current: 0.1 ... 1.0 mA)</li> <li>■ Face-sensitive Pt100 (measuring current 0.1 ... 1.0 mA) <sup>1)</sup></li> <li>■ Pt1000 (measuring current: 0.1 ... 0.3 mA)</li> <li>■ Face-sensitive Pt1000 (measuring current 0.1 ... 0.3 mA) <sup>1)</sup></li> </ul>	
→ For detailed specifications for Pt sensors, see Technical information IN 00.17 at <a href="http://www.wika.com">www.wika.com</a> .		
<b>Connection method</b>		
4 ... 20 mA version (models TR21-C-xTT, TR21-C-xTB)	2-wire	The lead resistance is recorded as an error in the measurement
Pt100 (model TR21-C-xPx)/Pt1000 (model TR21-C-xRx) version	3-wire	With a cable length of 30 m or longer, measuring deviations can occur
	4-wire	The lead resistance can be ignored
<b>Tolerance value of the measuring element <sup>2)</sup> per IEC 60751</b>		
4 ... 20 mA version (models TR21-C-xTT, TR21-C-xTB)	Class A	
Pt100 (model TR21-C-xPx)/Pt1000 (model TR21-C-xRx) version	<ul style="list-style-type: none"> <li>■ Class AA</li> <li>■ Class A</li> </ul>	

1) Face-sensitive measuring resistors, through their small design they serve to reduce the heat dissipation with short insertion lengths. Available for the temperature range up to 150 °C (302 °F). For protection tube insertion lengths of less than 50 mm, face-sensitive measuring resistors are recommended. For protection tube insertion lengths of less than 11 mm, face-sensitive measuring resistors are generally used.

2) Depending on the process connection, the deviation can be greater.

Accuracy specifications	
<b>Measuring deviation of the transmitter per IEC 62828</b>	±0.25 K
<b>Total measuring deviation in accordance with IEC 62828</b>	Measuring deviation of the measuring element + transmitter
<b>Influence of the ambient temperature</b>	0.1 % of span / 10 K T <sub>a</sub>
<b>Influence of supply voltage</b>	±0.025 % / V (depending on the supply voltage U <sub>B</sub> )
<b>Influence of the load</b>	±0.05 % / 100 Ω
<b>Linearisation</b>	Linear to temperature per IEC 60751
<b>Linearisation error</b>	±0.1 % <sup>1)</sup> of the set measuring span
<b>Reference conditions</b>	
Ambient temperature T <sub>a</sub> ref	23 °C
Supply voltage U <sub>B</sub> ref	DC 12 V

1) ±0.2 % for start of measuring range less than 0 °C (32 °F)

## Example calculation: Total measuring deviation

(measuring range 0 ... 150 °C, load 200 Ω, supply voltage 16 V, ambient temperature 33 °C, process temperature 100 °C)

Sensor element (class A per IEC 60751: 0.15+ (0.0020(t))):	±0.350 K
Measuring deviation of the transmitter ±0.25 K:	±0.250 K
Output error ±(0.1 % of 150 K):	±0.150 K
Effect of load ±(0.05 % / 100 Ω of 150 K):	±0.150 K
Influence of supply voltage ±(0.025 % / V of 150 K):	±0.150 K
Influence of the ambient temperature ±(0.1 % / 10 K T <sub>a</sub> of 150 K):	±0.150 K

**Measuring deviation (typical)**

$$\sqrt{0.35 K^2 + 0.25 K^2 + 0.15 K^2 + 0.15 K^2 + 0.15 K^2}$$

$$\sqrt{0.275 K^2} = 0.524 K$$

**Measuring deviation (maximum)**

$$0.35 K + 0.25 K + 0.15 K + 0.15 K + 0.15 K + 0.15 K = 1.2 K$$

Measuring range	
<b>Temperature range</b>	
4 ... 20 mA version (models TR21-C-xTT, TR21-C-xTB)	<ul style="list-style-type: none"> <li>■ -30 ... +150 °C [-22 ... +302 °F]</li> <li>■ -30 ... +250 °C [-22 ... +482 °F] <sup>1)</sup></li> </ul>
Pt100 (model TR21-C-xPx)/Pt1000 (model TR21-C-xRx) version	Class AA 0 ... 150 °C [32 ... 302 °F]
	Class A -30 ... +250 °C [-22 ... +482 °F]
<b>Unit</b>	
4 ... 20 mA version (models TR21-C-xTT, TR21-C-xTB)	Configurable °C, °F, K
<b>Temperature at the connector</b>	Max. 85 °C [185 °F]
<b>Measuring span</b>	
4 ... 20 mA version (models TR21-C-xTT, TR21-C-xTB)	Minimum 20 K, maximum 300 K

1) The temperature transmitter should therefore be protected from temperatures over 85 °C [185 °F].

Process connection	
<b>Type of process connection</b>	<ul style="list-style-type: none"> <li>■ Clamp</li> <li>■ VARINLINE®</li> <li>■ NEUMO BioControl®</li> <li>■ Union nut DIN 11851</li> <li>■ Tapered hygienic threaded connections</li> <li>■ Ingold connection</li> </ul>
<b>Protection tube</b>	
Protection tube design	→ see drawings from page 11
Protection tube diameter	<ul style="list-style-type: none"> <li>■ 6 mm</li> <li>■ Protection tube tip stepped down to 4.5 mm (from U<sub>1</sub> &gt; 25 mm)</li> </ul>
Surface roughness	<ul style="list-style-type: none"> <li>■ R<sub>a</sub> ≤ 0.76 μm (SF3 per ASME BPE)</li> <li>■ R<sub>a</sub> ≤ 0.38 μm (SF4 per ASME BPE)</li> <li>■ R<sub>a</sub> ≤ 0.38 μm electropolished (SF4 per ASME BPE)</li> </ul>
Insertion length U <sub>1</sub> <sup>1)</sup>	<ul style="list-style-type: none"> <li>■ 25 mm</li> <li>■ 50 mm</li> <li>■ 75 mm</li> <li>■ 100 mm</li> <li>■ 150 mm</li> <li>■ 200 mm</li> </ul>
	Other insertion lengths on request
Material (wetted)	Stainless steel 1.4435 (316L, UNS S31603)

1) For the TR21-C design without protection tube, the insertion length is defined by the dimension I1 (see dimensions in mm).  
The thickness of bottom of the protection tube can be neglected for dimensioning. It is offset by the spring travel of the measuring insert.

→ For dimensions, see dimension tables from page 11

VARINLINE® is a registered trademark of the company GEA Tuchenhausen (former designation: VARIVENT®).  
BioControl® is a registered trademark of the company NEUMO.

Output signal (4 ... 20 mA version, models TR21-C-xTT, TR21-C-xTB)	
<b>Analogue output</b>	4 ... 20 mA, 2-wire
<b>Load <math>R_A</math></b>	$R_A \leq (U_B - 10 \text{ V}) / 23 \text{ mA}$ with $R_A$ in $\Omega$ and $U_B$ in V The permissible load depends on the loop supply voltage. For communication with the instrument with programming unit PU-548, a max. load of 350 $\Omega$ is admissible.
<b>Load diagram</b>	<p>The load diagram is a graph with 'Load <math>R_A</math> in <math>\Omega</math>' on the vertical axis and 'Voltage <math>U_B</math> in V' on the horizontal axis. The vertical axis has markings at 583, 833, and 1083. The horizontal axis has markings at 10, 24, 30, and 36. A solid line starts at (10, 0) and goes up to (36, 1083). Dashed lines connect the points (24, 583) and (30, 833) to their respective values on both axes. The area under the line from <math>U_B = 30</math> V to <math>U_B = 36</math> V is shaded with diagonal lines and labeled 'Not for instruments with Ex version'.</p>
<b>Factory configuration</b>	
Measuring range	Measuring range 0 ... 150 °C [32 ... 302 °F] Other measuring ranges are adjustable
Current signals for error signalling	Configurable in accordance with NAMUR NE 043 downscale $\leq 3.6 \text{ mA}$ upscale $\geq 21.0 \text{ mA}$
Current value for sensor short-circuit	Not configurable in accordance with NAMUR NE 043 downscale $\leq 3.6 \text{ mA}$
<b>Communication</b>	
Info data	Tag no., description and user message can be stored in transmitter
Configuration and calibration data	Permanently stored
Configuration software	WIKAsoft-TT → Configuration software (multilingual) as a download from <a href="http://www.wika.com">www.wika.com</a>
<b>Voltage supply</b>	
Supply voltage $U_B$	DC 10 ... 30 V
Supply voltage input	Protected against reverse polarity
Permissible residual ripple of supply voltage	10 % generated by $U_B < 3 \%$ ripple of the output current
<b>Time response</b>	
Switch-on delay, electrical	Max. 4 s (time before the first measured value)
Warm-up time	After approx. 4 minutes, the instrument will function to the specifications (accuracy) given in the data sheet.
Response time (per IEC 60751)	$t_{50} < 3.3 \text{ s}$ $t_{90} < 9.7 \text{ s}$

Electrical connection	
Connection type	M12 x 1 circular connector (4-pin)
Material	Stainless steel 1.4404

### Pin assignment

Output signal 4 ... 20 mA  
M12 x 1 circular connector (4-pin)

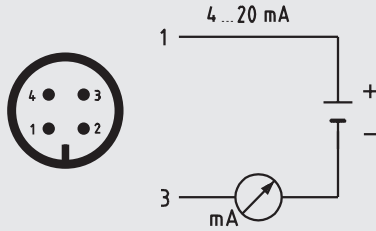

Output signal Pt100 sensor  
M12 x 1 circular connector (4-pin)

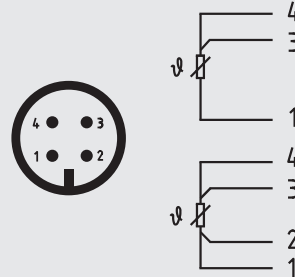



Pin	Signal	Description
1	L+	10 ... 30 V
2	VQ	not connected
3	L-	0 V
4	C	not connected

Operating conditions	
<b>Ambient temperature range</b>	
Models TR21-C-xTT, TR21-C-xTB	-40 ... +85 °C [-40 ... +185 °F]
Models TR21-C-xPx, TR21-C-xRx	-50 ... +85 °C [-58 ... +185 °F]
<b>Storage temperature range</b>	
-40 ... +85 °C [-40 ... +185 °F]	
<b>Climate class per IEC 60654-1</b>	
Models TR21-C-xTT, TR21-C-xTB	Cx (-40 ... +85 °C [-40 ... +185 °F], 5 ... 95 % r. h.)
Models TR21-C-xPx, TR21-C-xRx	Cx (-50 ... +85 °C [-58 ... +185 °F], 5 ... 95 % r. h.)
<b>Maximum permissible humidity, condensation</b>	100 % r. h., condensation allowed
<b>Max. operating pressure</b>	Dependent on particular process connection
<b>Salt fog</b>	IEC 60068-2-11
<b>Shock resistance per IEC 60068-2-27</b>	50 g, 6 ms, 3 axes, 3 directions, three times per direction
<b>Maximum permissible autoclaving conditions</b>	Max. 134 °C, 3 bar abs., 100 % r. h., duration 20 min., max. 50 cycles Autoclavable with mounted protective cap at coupler connector
<b>Conditions for outdoor use (only applies to UL approval)</b>	<ul style="list-style-type: none"> <li>■ The instrument is suitable for applications with pollution degree 3.</li> <li>■ The power supply must be suitable for operation above 2,000 m should the temperature transmitter be used at this altitude.</li> <li>■ The instrument shall be installed in locations sheltered from the weather.</li> <li>■ The instrument shall be installed sun/UV irradiation protected.</li> </ul>
<b>Ingress protection (IP code)</b>	
Case with connected connector <sup>1)</sup>	<ul style="list-style-type: none"> <li>■ IP67 per IEC/EN 60529</li> <li>■ IP69 per IEC/EN 60529</li> <li>■ IP69K per ISO 20653</li> </ul> <p>The stated ingress protection only applies when plugged in using line connectors that have the appropriate ingress protection.</p>
Coupler connector, not connected	IP67 per IEC/EN 60529
<b>Weight in kg</b>	approx. 0.3 ... 2.5 (depending on version)







1) Not tested with UL









## Approvals

### Approvals included in the scope of delivery

Logo	Description	Country
	<b>EU declaration of conformity</b>	European Union
	EMC directive <sup>1) 2)</sup> EN 61326 emission (group 1, class B) and immunity (industrial application) Configuration at 20 % of the full measuring range	
	RoHS directive	
	<b>UL - only for instrument version without explosion protection</b> Safety (e.g. electr. safety, overpressure, ...)	USA and Canada

### Optional approvals

Logo	Description	Country
 	<b>EU declaration of conformity</b>	European Union
	ATEX directive Hazardous areas Zone 0 gas II 1G Ex ia IIC T1 ... T6 Ga Zone 1 mounting to zone 0 gas II 1/2G Ex ia IIC T1 ... T6 Ga/Gb Zone 1 gas II 2G Ex ia IIC T1 ... T6 Gb Zone 20 dust II 1D Ex ia IIIC T135 °C Da Zone 21 mounting to zone 20 dust II 1/2D Ex ia IIIC T135 °C Da/Db Zone 21 dust II 2D Ex ia IIIC T135 °C Db	
	<b>IECEx - in combination with ATEX</b> Hazardous areas Zone 0 gas Ex ia IIC T1 ... T6 Ga Zone 1 mounting to zone 0 gas Ex ia IIC T1 ... T6 Ga/Gb Zone 1 gas Ex ia IIC T1 ... T6 Gb Zone 20 dust Ex ia IIIC T135 °C Da Zone 21 mounting to zone 20 dust Ex ia IIIC T135 °C Da/Db Zone 21 dust Ex ia IIIC T135 °C Db	International
	<b>CSA</b>	USA and Canada
	Safety (e.g. electr. safety, overpressure, ...) Hazardous areas Class I, division 1 or 2, groups A, B, C, D T1 ... T6 Class I, zone 0 or 1, IIC Ex/AEx ia IIC T1 ... T6 Ga Class II / III, division 1 or 2, groups E, F, G T1 ... T6 / 135 °C Class II / III, zone 20 or 21, Ex/AEx ia IIIC T135 °C Da	
 	<b>EAC</b>	Eurasian Economic Community
	EMC directive <sup>1)</sup> Hazardous areas Zone 0 gas 0Ex ia IIC T6 ... T1 Ga X Zone 1 gas 1Ex ia IIC T6 ... T1 Gb X Zone 1 gas Ex ia IIIC T135 °C Gb X Zone 1 mounting to zone 0 gas Ex ia IIC T6 ... T1 Ga/Gb X Zone 20 dust Ex ia IIIC T135 °C Da X Zone 20 dust Ex ia IIIC T80 ... T440 Da X Zone 21 dust Ex ia IIIC T80 ... T440 Db X	

Logo	Description	Country
	<b>Ex Ukraine</b> Hazardous areas Zone 0 gas II 1G Ex ia IIC T6 ... T1 Ga Zone 20 dust II 1D Ex ia IIIC T135 °C Da Zone 1 mounting to zone 0 gas II 1/2G Ex ia IIC T6 ... T1 Ga/Gb Zone 21 mounting to zone 20 dust II 1/2D Ex ia IIIC T135 °C Da/Db Zone 1 gas II 2G Ex ia IIC T6 ... T1 Gb Zone 21 dust II 2D Ex ia IIIC T135 °C Db Zone 1 gas II 2G Ex ib IIC T6 ... T1 Gb Zone 21 dust II 2D Ex ib IIIC T135 °C Db Zone 1 mounting to zone 0 gas II 1/2G Ex ib IIC T6 ... T1 Ga/Gb Zone 21 mounting to zone 20 dust II 1/2D Ex ib IIIC T135 °C Da/Db	Ukraine
	<b>CCC <sup>3)</sup></b> Hazardous areas Zone 0 gas Ex ia IIC T1~T6 Ga Zone 1 gas Ex ia IIC T1~T6 Gb Zone 1 mounting to zone 0 gas Ex ia IIC T1~T6 Ga/Gb Zone 20 dust Ex iaD 20 T135 Zone 21 dust Ex iaD 21 T135 Zone 21 mounting to zone 20 dust Ex iaD 20/21 T135	China
	<b>GOST</b> Metrology, measurement technology	Russia
	<b>KazInMetr</b> Metrology, measurement technology	Kazakhstan
-	<b>MTSCHS</b> Permission for commissioning	Kazakhstan
	<b>BelGIM</b> Metrology, measurement technology	Belarus
	<b>Uzstandard</b> Metrology, measurement technology	Uzbekistan
	<b>3-A <sup>4)</sup></b> Sanitary Standard	USA
	<b>EHEDG <sup>4)</sup></b> Hygienic Equipment Design	European Union

1) Only for built-in transmitter

2) During transient interferences (e.g. burst, surge, ESD) take into account an increased measuring deviation of up to 2 %.

3) Not for built-in transmitter

4) Confirmation of 3-A or EHEDG conformity only valid with separately selectable 2.2 test report

Instruments marked with “ia” may also be used in areas only requiring instruments marked with “ib” or “ic”.

If an instrument with “ia” marking has been used in an area with requirements in accordance with “ib” or “ic”, it can no longer be operated in areas with requirements in accordance with “ia” afterwards.

## Certificates (option)

Certificates		
<b>Certificates</b>	<ul style="list-style-type: none"> <li>■ 2.2 test report</li> <li>■ 3.1 inspection certificate</li> <li>■ DKD/DAkkS calibration certificate</li> <li>■ Manufacturer's declaration regarding regulation (EC) 1935/2004 and (EC) 2023/2006</li> <li>■ Certificate of the surface roughness of wetted parts</li> </ul>	
<b>Hygienic certificates</b>	3-A approval	EHEDG approval
Clamp	c	Yes <sup>2)</sup>
VARINLINE®	Yes	Yes
NEUMO BioControl®	Yes	No
Union nut DIN 11851	Yes <sup>1)</sup>	Yes <sup>2)</sup>
Tapered hygienic threaded connections	No	No
Ingold connection	No	No

1) In combination with  
 - ASEPTO-STAR k-flex upgrade gaskets from Kieselmann GmbH, Germany or  
 - SKS gasket set DIN 11851 EHEDG from Siersema Componenten Service (S.K.S.) B.V., Netherlands

2) In combination with  
 T-ring seals from Combifit International B. V., Netherlands

The minimum length (metal part of the probe or the length of the probe below the process connection) for carrying out a measurement accuracy test 3.1 or DKD/DAkkS is 100 mm. Calibration of shorter lengths on request.

Approvals and certificates, see website



## Safety-relevant characteristic values for explosion-protected version (option)

### Thermometer with transmitter and 4 ... 20 mA output signal (models TR21-C-xTT, TR21-C-xTB)

Marking:

Hazardous gas atmosphere	Temperature class	Ambient temperature range ( $T_a$ )	Maximum surface temperature ( $T_{max}$ ) at the tip of the probe or protection tube
II 1G Ex ia IIC T1 - T6 Ga II 1/2G Ex ia IIC T1 - T6 Ga/Gb II 2G Ex ia IIC T1 - T6 Gb	T6	-40 ... +45 °C	T <sub>M</sub> (medium temperature) + self-heating (15 K) Pay attention to the special conditions for safe use.
	T5	-40 ... +60 °C	
	T4	-40 ... +85 °C	
	T3	-40 ... +85 °C	
	T2	-40 ... +85 °C	
	T1	-40 ... +85 °C	

Hazardous dust atmosphere	Power $P_i$	Ambient temperature range ( $T_a$ )	Maximum surface temperature ( $T_{max}$ ) at the tip of the probe or protection tube
II 1D Ex ia IIIC T135 °C Da II 1/2D Ex ia IIIC T135 °C Da/Db II 2D Ex ia IIIC T135 °C Db	750 mW	-40 ... +40 °C	T <sub>M</sub> (medium temperature) + self-heating (15 K) Pay attention to the special conditions for safe use.
	650 mW	-40 ... +70 °C	
	550 mW	-40 ... +85 °C	

Safety-related maximum values for the current loop circuit (+ and - connections):

Parameters	Hazardous gas atmosphere	Hazardous dust atmosphere
Terminals	+ / -	+ / -
Voltage $U_i$	DC 30 V	DC 30 V
Current $I_i$	120 mA	120 mA
Power $P_i$	800 mW	750/650/550 mW
Effective internal capacitance $C_i$	29.7 nF	29.7 nF
Effective internal inductance $L_i$	Negligible	Negligible
Maximum self-heating at the probe or protection tube tip	15 K	15 K

### Thermometer with direct sensor output with Pt100 (model TR21-C-xPx) or Pt1000 (model TR21-C-xRx)

Marking:

Marking	Temperature class	Ambient temperature range ( $T_a$ )	Maximum surface temperature ( $T_{max}$ ) at the tip of the probe or protection tube
II 1G Ex ia IIC T1 - T6 Ga II 1/2G Ex ia IIC T1 - T6 Ga/Gb II 2G Ex ia IIC T1 - T6 Gb	T6	-50 ... +80 °C	T <sub>M</sub> (medium temperature) + self-heating Pay attention to the special conditions for safe use.
	T5	-50 ... +85 °C	
	T4	-50 ... +85 °C	
	T3	-50 ... +85 °C	
	T2	-50 ... +85 °C	
	T1	-50 ... +85 °C	

Marking	Power $P_i$	Ambient temperature range ( $T_a$ )	Maximum surface temperature ( $T_{max}$ ) at the tip of the probe or protection tube
II 1D Ex ia IIIC T135 °C Da II 1/2D Ex ia IIIC T135 °C Da/Db II 2D Ex ia IIIC T135 °C Db	750 mW	-50 ... +40 °C	T <sub>M</sub> (medium temperature) + self-heating Pay attention to the special conditions for safe use.
	650 mW	-50 ... +70 °C	
	550 mW	-50 ... +85 °C	

Safety-related maximum values for the current loop circuit (connections in accordance with pin assignment 1 - 4):

Parameters	Gas applications	Dust applications
Terminals	1 - 4	1 - 4
Voltage $U_i$	DC 30 V	DC 30 V
Current $I_i$	550 mA	250 mA
Power $P_i$	1,500 mW	750/650/550 mW
Effective internal capacitance $C_i$	Negligible	Negligible
Effective internal inductance $L_i$	Negligible	Negligible
Maximum self-heating at the probe or protection tube tip	$(R_{th}) = 335 \text{ K/W}$	$(R_{th}) = 335 \text{ K/W}$

## Overview of the process connections

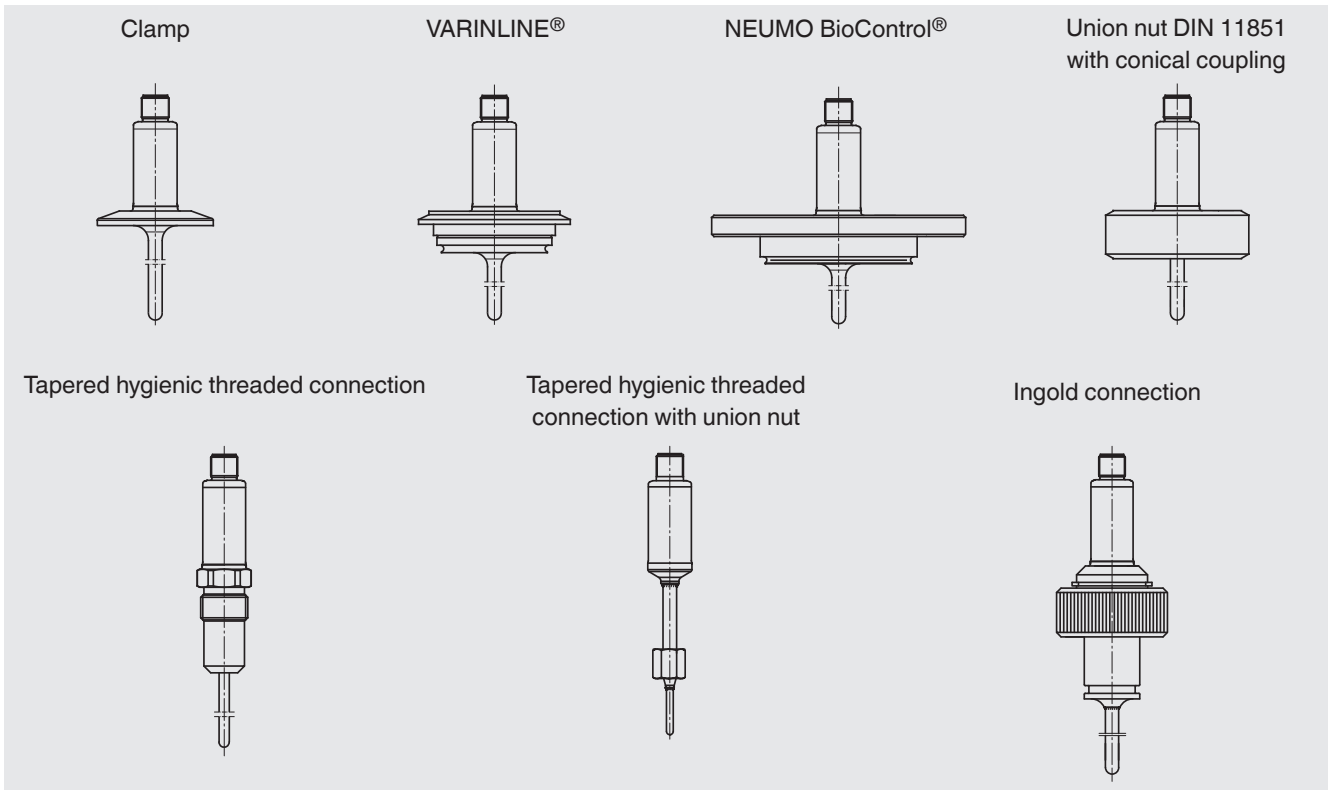

VARINLINE® is a registered trademark of the company GEA Tuchenhagen (former designation: VARIVENT®).  
BioControl® is a registered trademark of the company NEUMO.

# Dimensions of the process connections in mm

## Clamp process connection

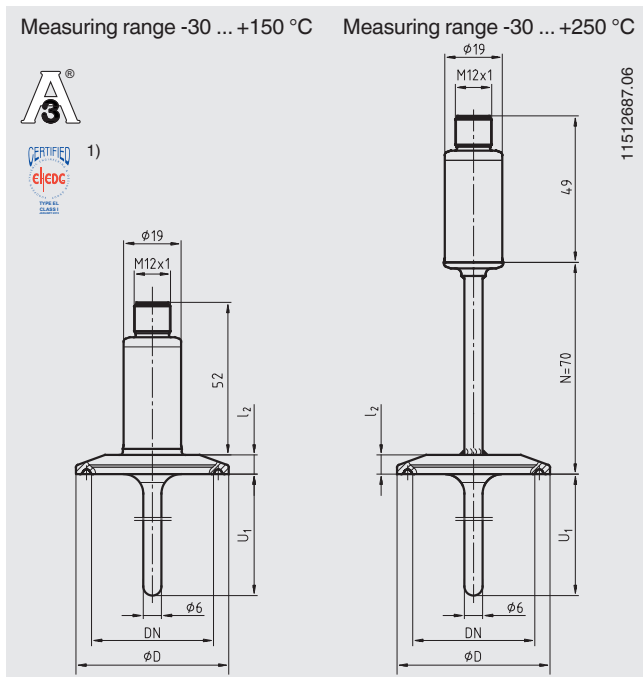

## VARINLINE® process connection

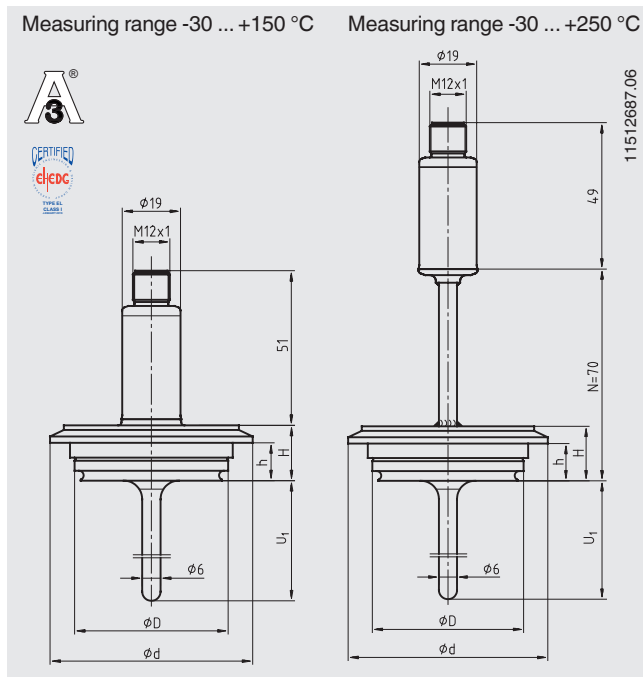

1) In combination with T-ring seals from Combifit International B. V., Netherlands

## Dimensions for clamp process connection

Process connection	Nominal width in mm/inch	PN in bar	Dimensions in mm		Weight in kg
			$\phi D$	$l_2$	
DIN 32676 for pipes per DIN 11866 row A 1)	DN 10 ... 20	25	34.0	6.35	0.2
	DN 25 ... 40	25	50.5	6.35	0.3
	DN 50	16	64.0	6.35	0.4
DIN 32676 for pipes per DIN 11866 row B	13.5 ... 17.2	25	25.0	4.75	0.2
	21.3 ... 33.7	25	50.5	6.35	0.3
	42.4 ... 48.3	16	64.0	6.35	0.3
DIN 32676 for pipes per DIN 11866 row C	1/2" ... 3/4"	25	25.0	4.75	0.2
	1" ... 1 1/2"	25	50.5	6.35	0.3
	2"	16	64.0	6.35	0.4
TRI-CLAMP®	1/2" ... 3/4"	13.8	25.0	4.75	0.2
	1" ... 1 1/2"	13.8	50.5	6.35	0.3
	2"	13.8	64.0	6.35	0.4
	2 1/2"	13.8	77.5	6.35	0.5
	3"	13.8	91.0	6.35	0.6
	4"	13.8	119.0	6.35	0.8

1) Process connection identical in construction to ISO 2852

## Dimensions for VARINLINE® process connection

Process connection	Nominal width in mm	PN in bar	Dimensions in mm				Weight in kg
			$\phi D$	$\phi d$	H	h	
Form B	DN 10, DN 15	25	31	52.7	20	13.65	0.3
Form F	DN 25, DN 32	25	50	66.0	18	12.30	0.4
Form N	DN 40, DN 50	25	68	84.0	18	12.30	0.6

TRI-CLAMP® is a trademark of the company Alfa Laval AB SE.  
VARINLINE® is a registered trademark of the company GEA Tuchenhausen (former designation: VARIVENT®).

# NEUMO BioControl® process connection

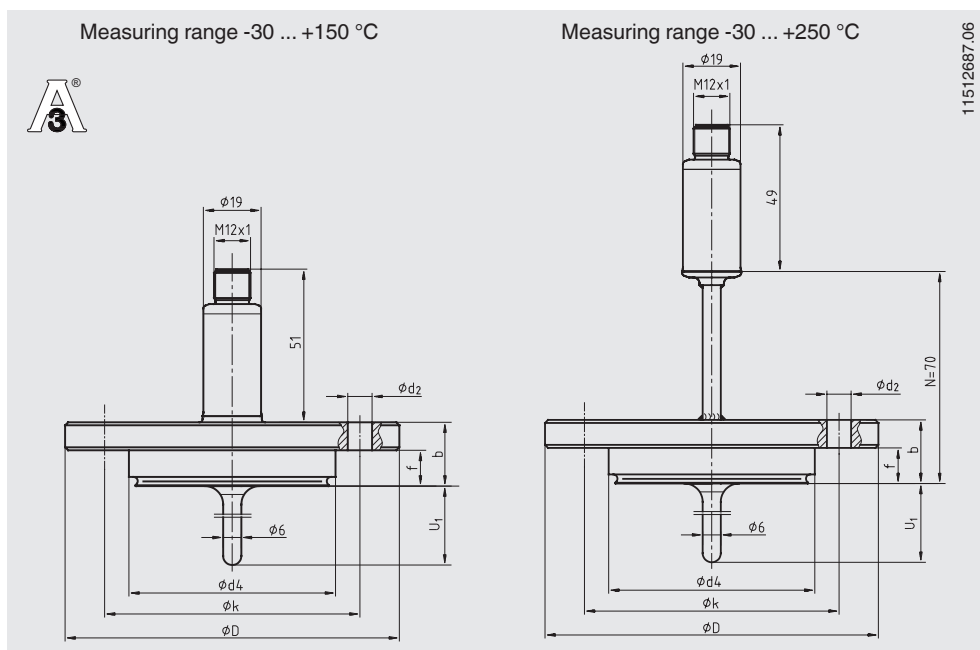

BioControl® is a registered trademark of the company NEUMO.

For a detailed description of the BioControl® cases, see data sheet AC 09.14.

Case size	Nominal width in mm	PN in bar	Dimensions in mm							Weight in kg
			U <sub>1</sub> <sup>2)</sup>	Ø d <sub>4</sub>	Ø D	f	b	Ø k	Ø d <sub>2</sub>	
Size 25	DN 8	16	5	30.5	64	11	20	50	4 x Ø 7	0.4
	DN 10	16	6	30.5	64	11	20	50	4 x Ø 7	0.4
	DN 15	16	9	30.5	64	11	20	50	4 x Ø 7	0.4
	DN 20	16	11	30.5	64	11	20	50	4 x Ø 7	0.4
Size 50	DN 25	16	15	50.0	90	17	27	70	4 x Ø 9	0.8
	DN 40	16	20	50.0	90	17	27	70	4 x Ø 9	0.8
	DN 50	16	25	50.0	90	17	27	70	4 x Ø 9	0.8
	DN 65	16	35	50.0	90	17	27	70	4 x Ø 9	0.8
	DN 80	16	45	50.0	90	17	27	70	4 x Ø 9	0.8
Size 65	DN 100	16	55	50.0	90	17	27	70	4 x Ø 9	0.8
	DN 40	16	20	68.0	120	17	27	95	4 x Ø 11	1.4
	DN 50	16	25	68.0	120	17	27	95	4 x Ø 11	1.4
	DN 65	16	35	68.0	120	17	27	95	4 x Ø 11	1.4
	DN 80	16	45	68.0	120	17	27	95	4 x Ø 11	1.4
	DN 100	16	55	68.0	120	17	27	95	4 x Ø 11	1.4

2) Recommended insertion length for installation in BioControl® flow-through housing; other insertion lengths are possible.

## Union nut process connection DIN 11851 with conical coupling (milk thread fitting)

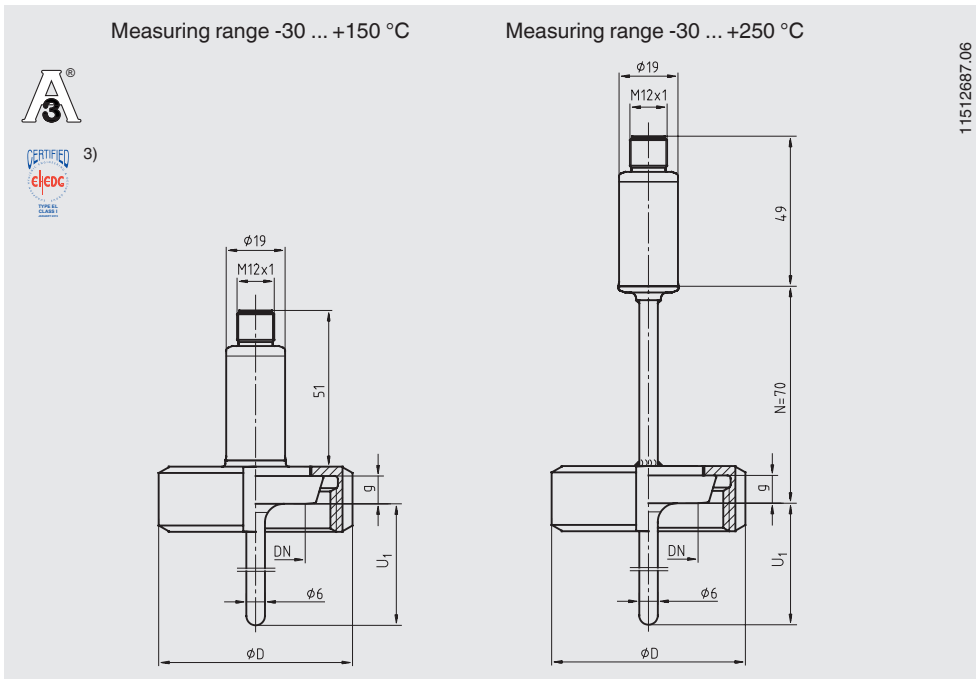

- 3) In combination with
- ASEPTO-STAR k-flex upgrade gaskets from Kieselmann GmbH, Germany or
  - SKS gasket set DIN 11851 EHEDG from Siersema Komponenten

Nominal width in mm	PN in bar	Dimensions in mm				Weight in kg
		$\phi d_6$	G	$\phi D$	g	
DN 20	40	36.5	RD 44 x 1/6	54	8	0.4
DN 25	40	44.0	RD 52 x 1/6	63	10	0.5
DN 32	40	50.0	RD 58 x 1/6	70	10	0.6
DN 40	40	56.0	RD 65 x 1/6	78	10	0.8
DN 50	25	68.5	RD 78 x 1/6	92	11	0.9

## Process connection, tapered hygienic threaded connections

### ■ Process connection G 1/2

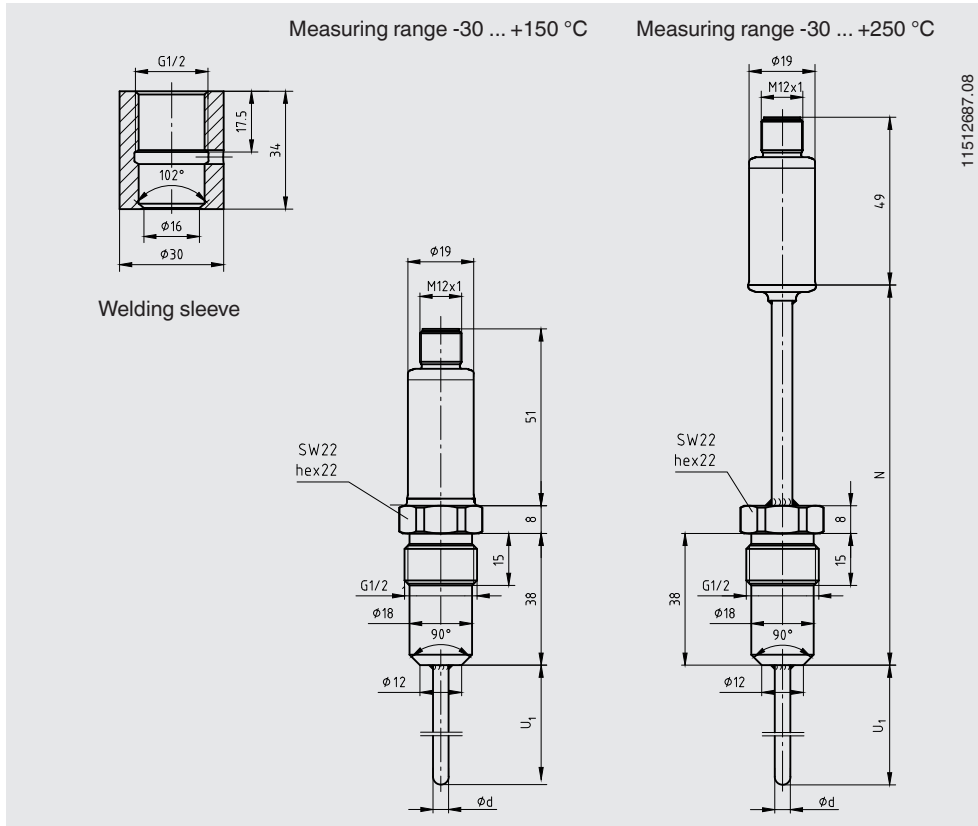

### ■ Process connection M12 x 1.5

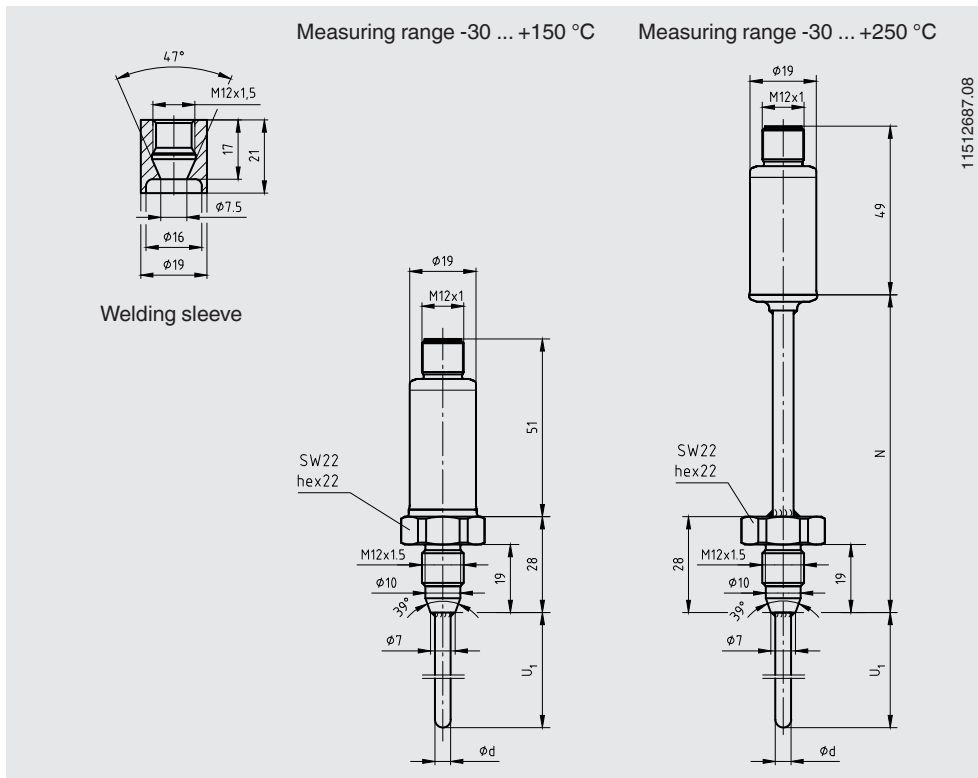

**Process connection, tapered hygienic threaded connections with union nut**

■ Process connection G 1/8

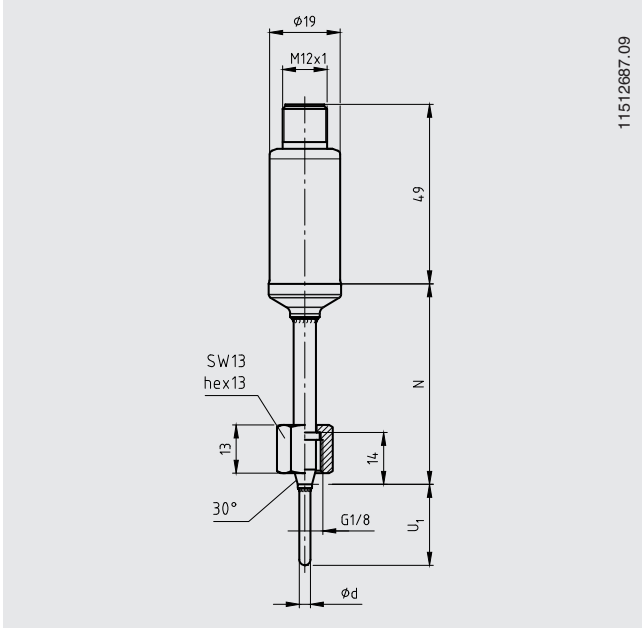

**Process connection, Ingold connection**

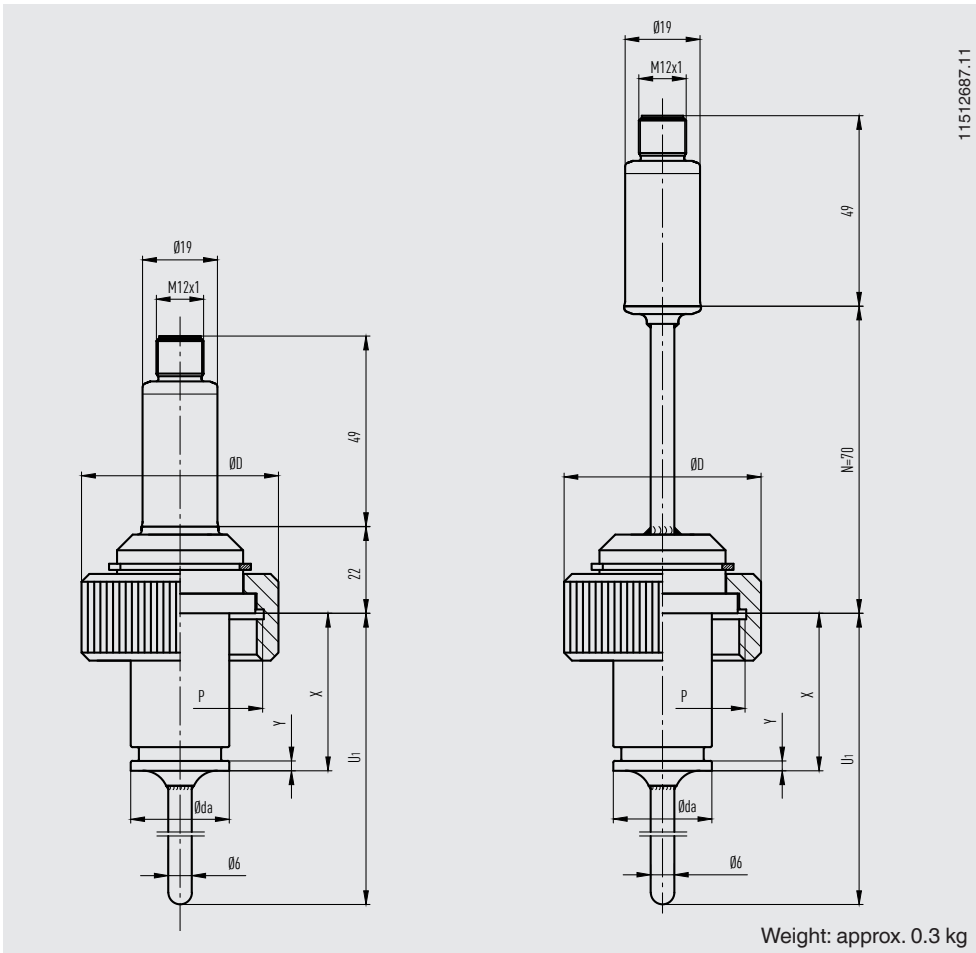

Further process connections and nominal widths available on request.

# Configuration software WIKAsoft-TT



Configuration software (multilingual) as a download from [www.wika.com](http://www.wika.com)

## Connecting the PU-548 programming unit

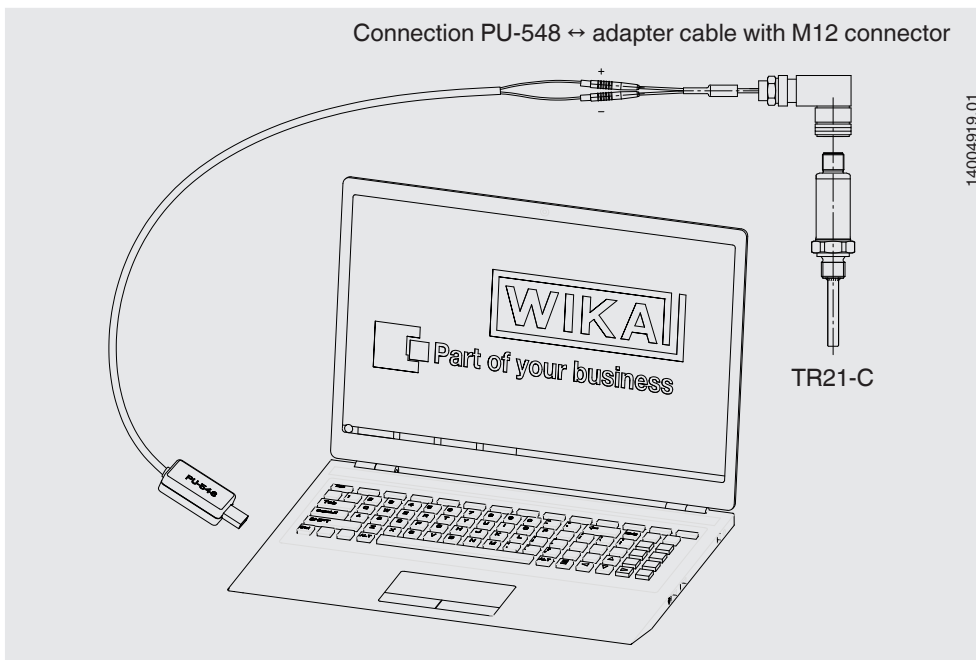

(predecessor, programming unit model PU-448, also compatible)



## Accessories

Model	Special features	Order no.	
<b>Programming unit</b> <b>Model PU-548</b> 	<ul style="list-style-type: none"> <li>■ Easy to use</li> <li>■ LED status display</li> <li>■ Compact design</li> <li>■ No further voltage supply needed, neither for the programming unit nor for the transmitter</li> </ul> <p>(replaces programming unit model PU-448)</p>	14231581	
<b>Adapter cable M12 to PU-548</b> 	Adapter cable for the connection of a model TR21-C resistance thermometer to the model PU-548 programming unit	14003193	
<b>M12 sealing cap with mounted PTFE sealing</b>	Sealing cap for protecting the resistance thermometer during sterilisation in autoclaves	14113588	
<b>M12 connection cable</b>	Cable socket straight, 4-pin, ingress protection IP67 <ul style="list-style-type: none"> <li>■ Temperature range -20 ... +80 °C</li> <li>■ Suitable for hazardous areas</li> </ul>	Cable length 2 m 14086880 Cable length 5 m 14086883	
	Cable socket straight, 4-pin, ingress protection IP69K, hygienic design <ul style="list-style-type: none"> <li>■ Temperature range -40 ... +80 °C</li> <li>■ Not for hazardous areas</li> </ul>	Cable length 3 m 14137167 Cable length 5 m 14137168	
	Angled socket, 4-pin, ingress protection IP67 <ul style="list-style-type: none"> <li>■ Temperature range -20 ... +80 °C</li> <li>■ Suitable for hazardous areas</li> </ul>	Cable length 2 m 14086889 Cable length 5 m 14086891	
	Angled socket, 4-pin, ingress protection IP69K, hygienic design <ul style="list-style-type: none"> <li>■ Temperature range -40 ... +80 °C</li> <li>■ Not for hazardous areas</li> </ul>	Cable length 3 m 14137169 Cable length 5 m 14137170	
	<b>Welding sleeves</b>	With G ½ tapered hygienic threaded connection Material: Stainless steel 1.4435 (316L)	11422599
		With M12 tapered hygienic threaded connection Material: Stainless steel 1.4435 (316L)	11426721
	<b>Weld-in help</b>	Weld-in mandrel for tapered hygienic threaded connection G ½ Material: CuZn alloy (brass)	11477742
		Weld-in mandrel for tapered hygienic threaded connection M12 Material: CuZn alloy (brass)	11476894

Welding sleeve G ½

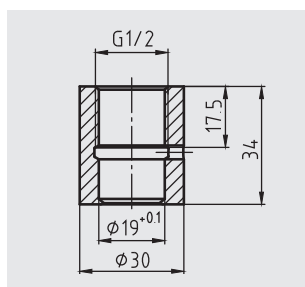

Welding sleeve M12

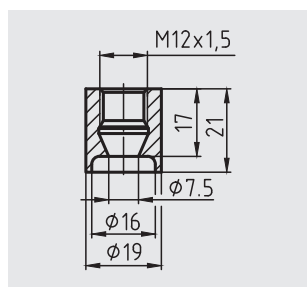

Weld-in mandrel G ½

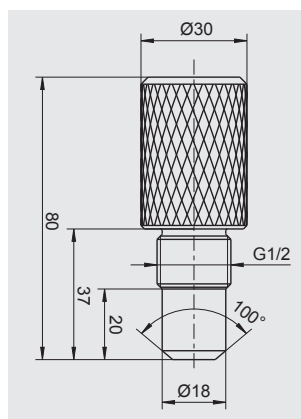

Weld-in mandrel M12

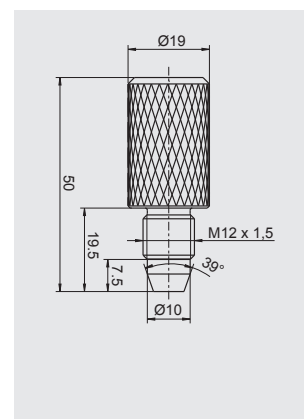

### Ordering information

Model / Approval / Sensor or transmitter output / Sensor specification or transmitter configuration / Process temperature / Process connection / Protection tube diameter / Material of wetted parts / Insertion length  $U_1$  / Neck length / Electrical accessories / Certificates / Options

© 12/2010 WIKA Alexander Wiegand SE & Co. KG, all rights reserved.  
The specifications given in this document represent the state of engineering at the time of publishing.  
We reserve the right to make modifications to the specifications and materials.



**WIKA Alexander Wiegand SE & Co. KG**  
Alexander-Wiegand-Straße 30  
63911 Klingenberg/Germany  
Tel. +49 9372 132-0  
Fax +49 9372 132-406  
info@wika.de  
www.wika.de